

# **SECTION 11**

## **Washdown**

# WRG\_0037F\_auger\_washdown\_coolantthru

## 1310 PIN LIST

- J1**
  - 120 VAC (INPUT)
  - PUMP
  - VALVE #1
  - VALVE #2
  - VALVE #3
  - 120 RETURN (INPUT)
  - E-STOP (INPUT)
  - CONTACTOR FOR AUGER
  - CONTACTOR FOR SPINDLE
  - RETURN FOR SPINDLE CONTACTOR
  - RETURN FOR AUGER CONTACTOR AND PUMP STARTER
  - RETURN FOR VALVE COILS
- J2**
  - 1-3. AUGER MOTOR
  - 4-7. 220 VAC
- J3**
  - START/STOP BUTTON
  - MODE SWITCH
  - M-FUNCTION INPUT
  - POT
  - +5V FOR POT
  - GROUND
  - EXTERNAL RESET
  - +5V
  - +5V (INPUT)
  - GROUND (INPUT)
  - EXTERNAL SLIDE HOLD OUTPUT
  - GROUND FOR EXTERNAL SLIDE HOLD
- J4**
  - LEFT DOOR SWITCH (BLK)
  - LEFT DOOR SWITCH (WHT)
  - LEFT DOOR SWITCH (RED)
  - LEFT DOOR SWITCH (GRN)
  - RIGHT DOOR SWITCH (BLK)
  - RIGHT DOOR SWITCH (WHT)
  - RIGHT DOOR SWITCH (RED)
  - RIGHT DOOR SWITCH (GRN)
  - FRONT DOOR SWITCH (BLK)
  - FRONT DOOR SWITCH (WHT)
  - FRONT DOOR SWITCH (RED)
  - FRONT DOOR SWITCH (GRN)

- K1 - SSR ELE-0070 TURN ON PUMP.
- K2 - SSR ELE-0070 VALVE 1.
- K3 - SSR ELE-0070 VALVE 2.
- K4 - SSR ELE-0070 VALVE 3.
- K6 - SSR ELE-0070 3 POLE RELAY 240V.
- K101 - SSR ELE-0101 SPINDLE RELAY

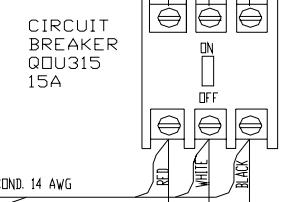
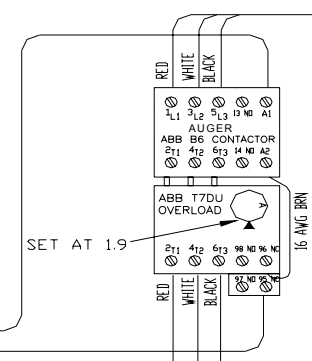
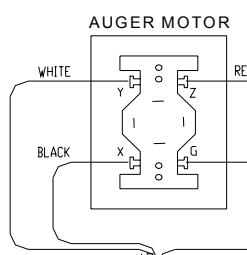
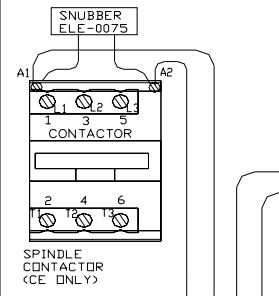

## T-820 TRANSFORMER

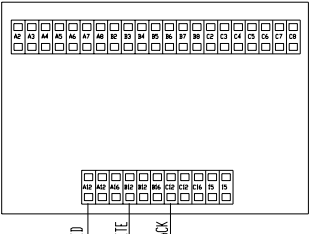

NOTE: IF MACHINE HAS ALSO HAS PALLET CHANGER AND DUAL ARM TDOL CHANGER THEN A SECOND 15 A CIRCUIT BREAKER WILL BE REQUIRED. UL LIMIT FOR BRANCH MOTOR PROTECTION IS 15 A.

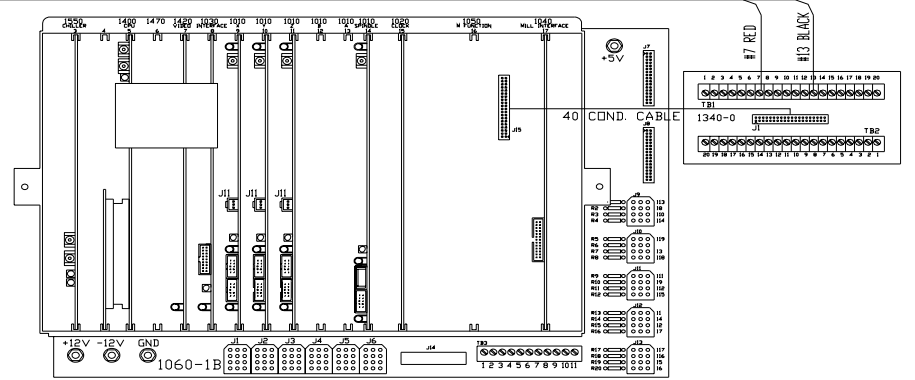
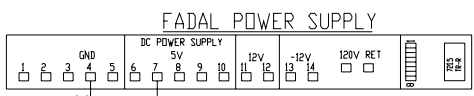
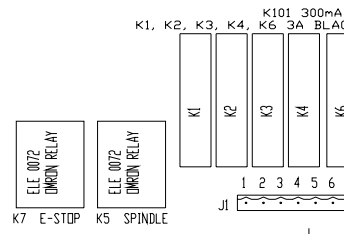
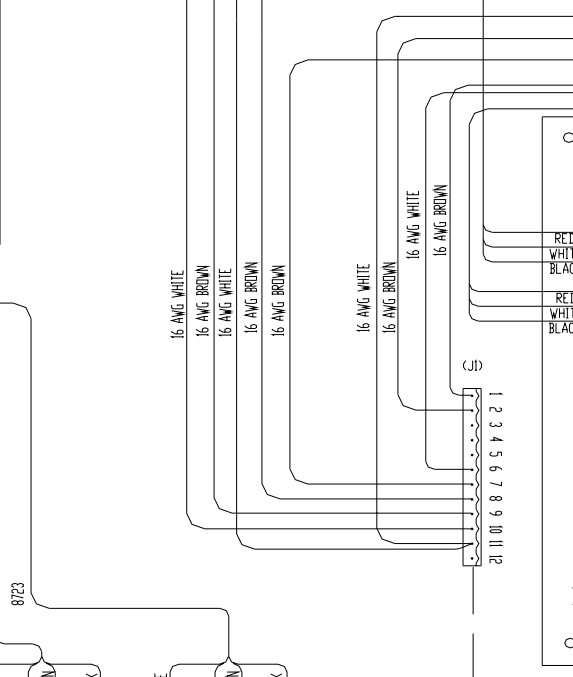
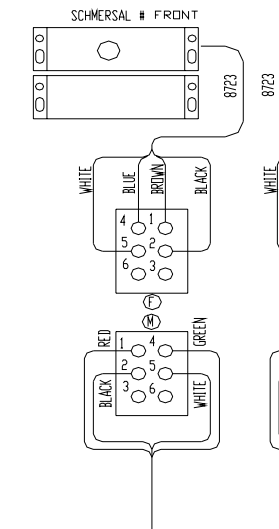
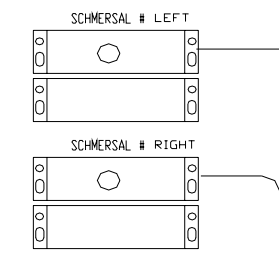
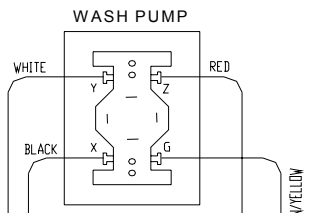
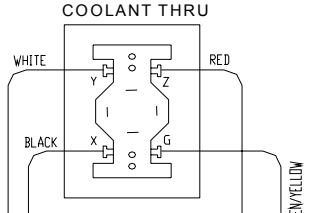
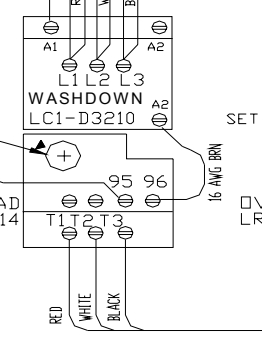
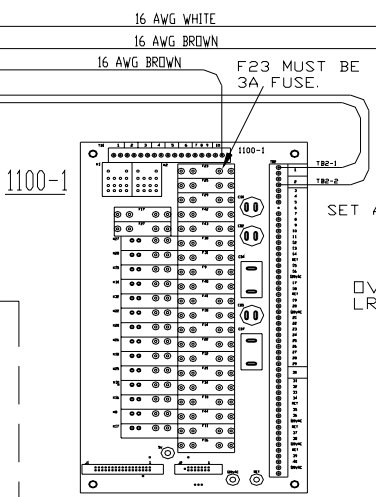

NOTE: REMOVE DOOR INTERLOCK FROM J13 PIN 8 & INSTALL AUGER INTERLOCK

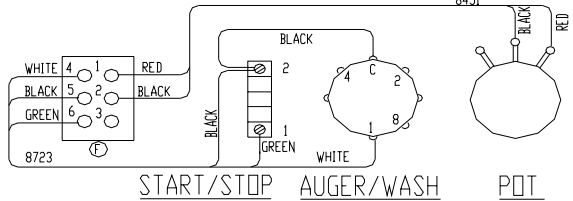

# WRG\_0044D\_6535\_washdown

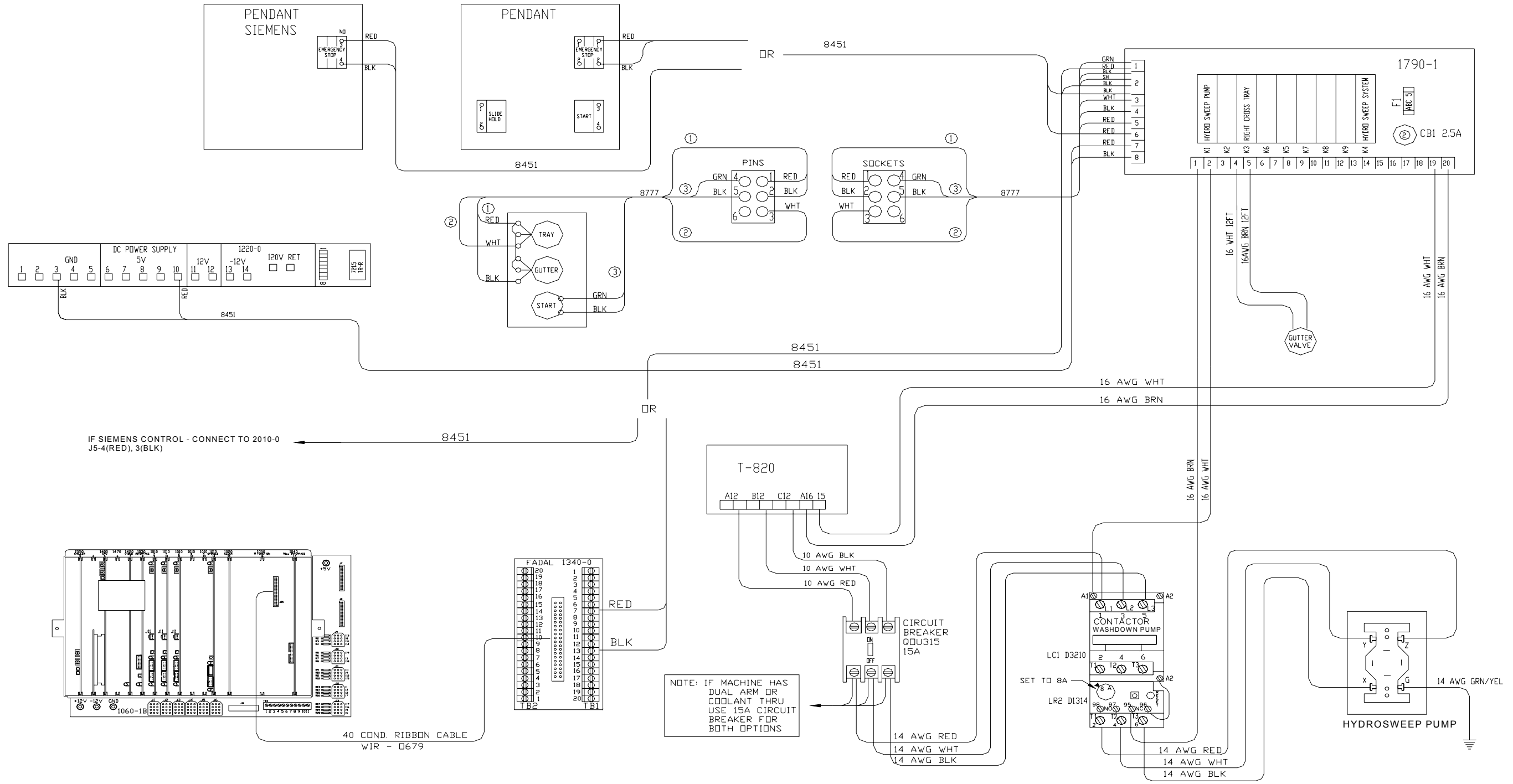

# Wrg\_0081X\_15of22\_hmc\_wash\_conv\_cool

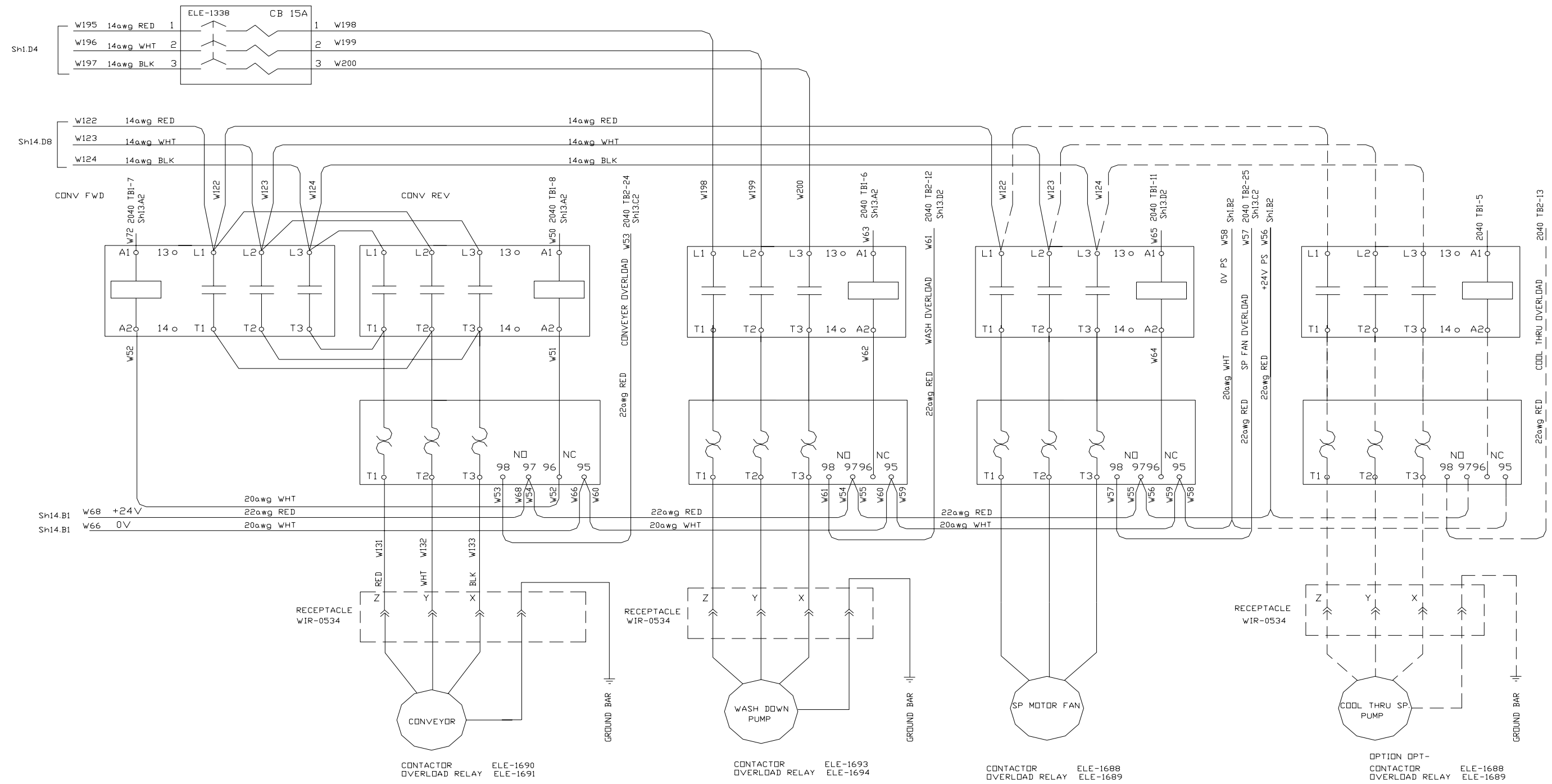

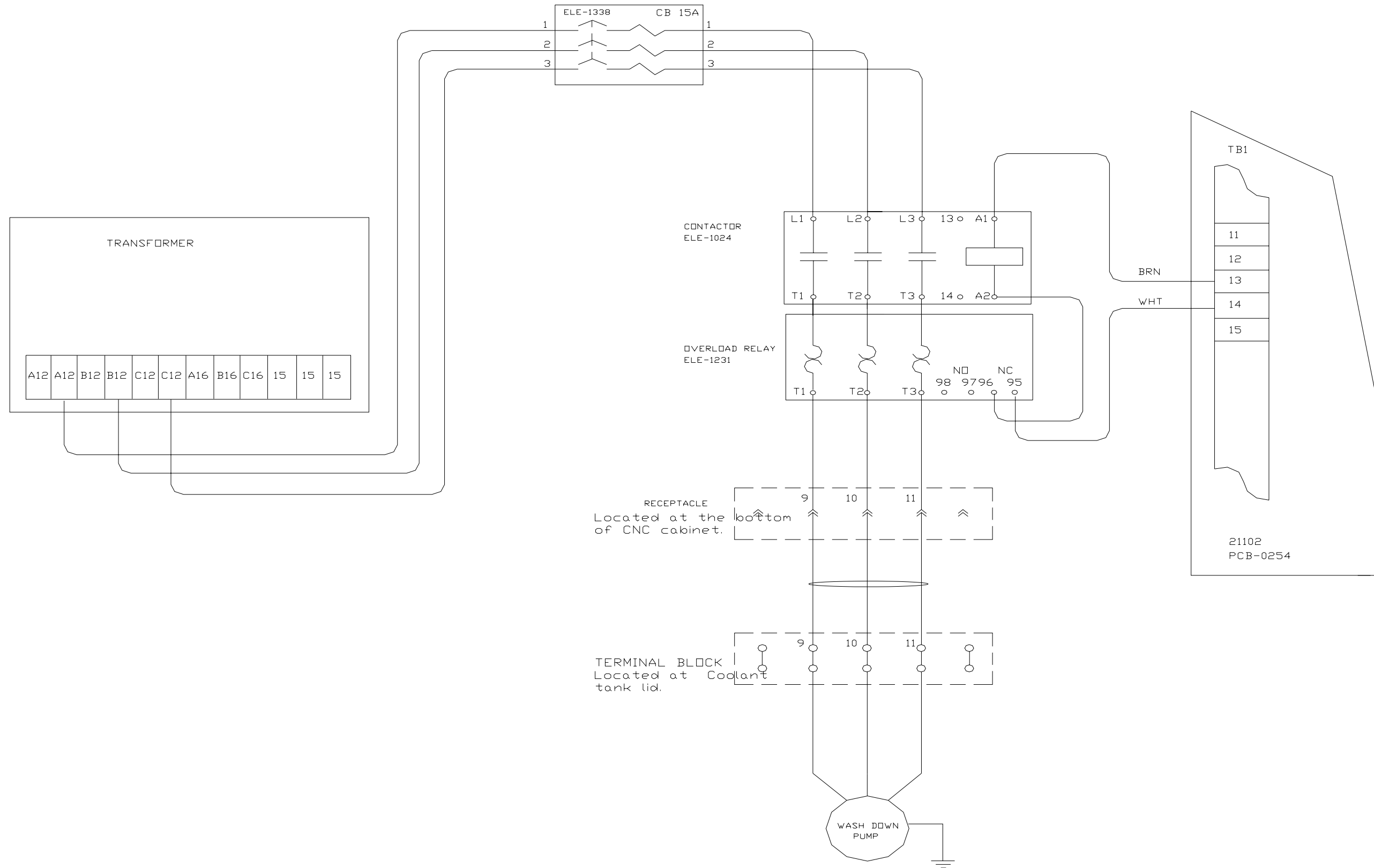

# WRG\_0693J\_auger\_washdown\_wiring\_diagram

## 1310 PIN LIST

- J1**
- 120 VAC (INPUT)
  - PUMP
  - VALVE #1
  - VALVE #2
  - VALVE #3
  - 120 RETURN (INPUT)
  - E-STOP (INPUT)
  - CONTACTOR FOR AUGER
  - CONTACTOR FOR SPINDLE
  - RETURN FOR SPINDLE CONTACTOR
  - RETURN FOR AUGER CONTACTOR
  - AND PUMP STARTER
  - RETURN FOR VALVE COILS
- J2**
- 1-3. AUGER MOTOR
  - 4-7. 220 VAC
- J3**
- START/STOP BUTTON
  - MODE SWITCH
  - M-FUNCTION INPUT
  - POT
  - +5V FOR POT
  - GROUND
  - EXTERNAL RESET
  - +5V
  - +5V (INPUT)
  - GROUND (INPUT)
  - EXTERNAL SLIDE HOLD OUTPUT
  - GROUND FOR EXTERNAL SLIDE HOLD
- J4**
- LEFT DOOR SWITCH (BLK)
  - LEFT DOOR SWITCH (WHT)
  - LEFT DOOR SWITCH (RED)
  - LEFT DOOR SWITCH (GRN)
  - RIGHT DOOR SWITCH (BLK)
  - RIGHT DOOR SWITCH (WHT)
  - RIGHT DOOR SWITCH (RED)
  - RIGHT DOOR SWITCH (GRN)
  - FRONT DOOR SWITCH (BLK)
  - FRONT DOOR SWITCH (WHT)
  - FRONT DOOR SWITCH (RED)
  - FRONT DOOR SWITCH (GRN)

- K1 - SSR ELE-0070 TURN ON PUMP.**  
**K2 - SSR ELE-0070 VALVE 1.**  
**K3 - SSR ELE-0070 VALVE 2.**  
**K4 - SSR ELE-0070 VALVE 3.**  
**K6 - SSR ELE-0070 3 POLE RELAY 240V.**  
**K101 - SSR ELE-0101 SPINDLE RELAY**

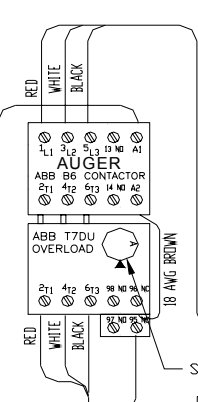
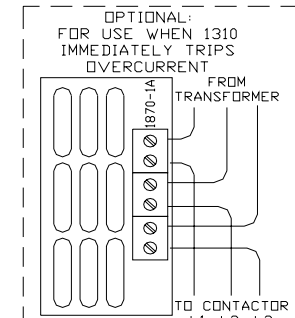
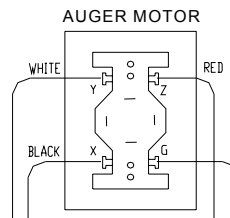
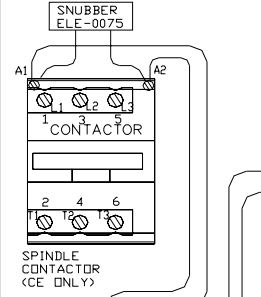

CIRCUIT BREAKER  
 15A QDU315  
 (IF MORE THAN 15A IS  
 REQUIRED BECAUSE  
 DATC, PALLET CHANGER,  
 AND COOLANT THRU ARE  
 ADDED, THEN A SECOND  
 CIRCUIT BREAKER WILL  
 BE NEEDED.)

NOTE:  
 IF MACHINE HAS COOLANT THRU  
 SEE WRG-0037.  
 IF MACHINE HAS COOLANT THRU,  
 DATC, AND PALLET CHANGER,  
 A SECOND 15A CIRCUIT BREAKER  
 WILL BE NEEDED.

## T-820 TRANSFORMER

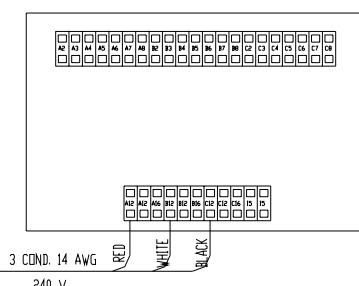

3 COND. 14 AWG  
 240 V

3 COND. 14 AWG

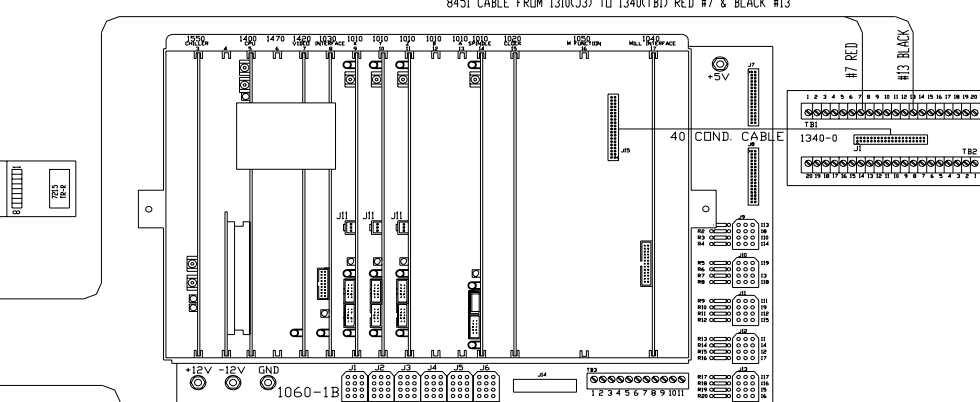
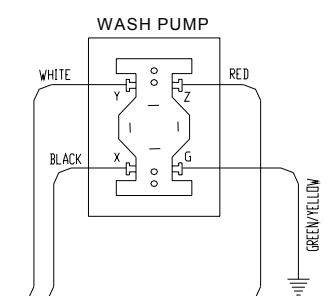
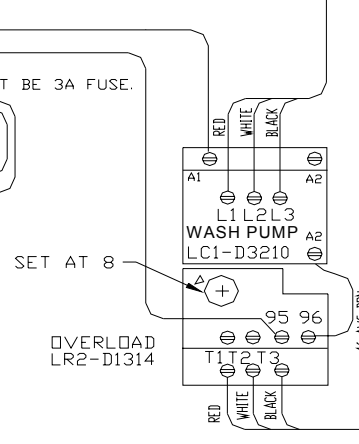
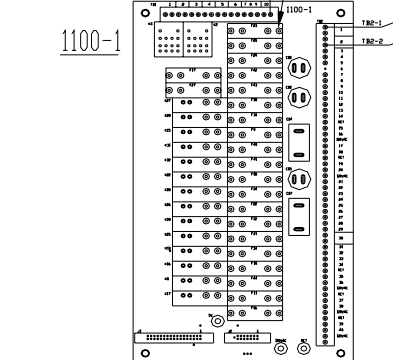
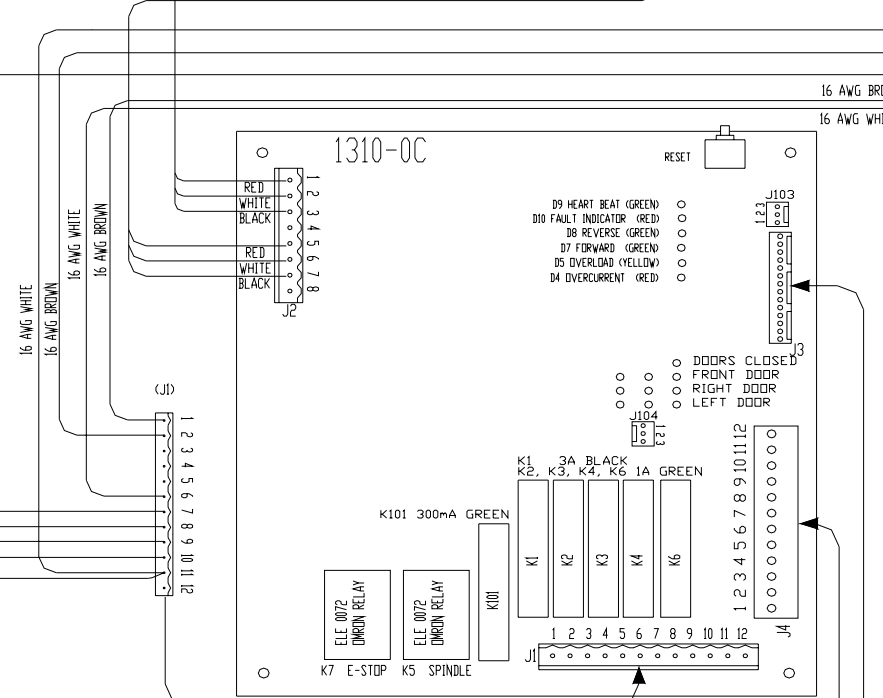

20 AWG PINK J13 #8

NOTE:  
 REMOVE DOOR INTERLOCK FROM J13  
 PIN 8 & INSTALL AUGER INTERLOCK

